

18t

18t

動臂系列

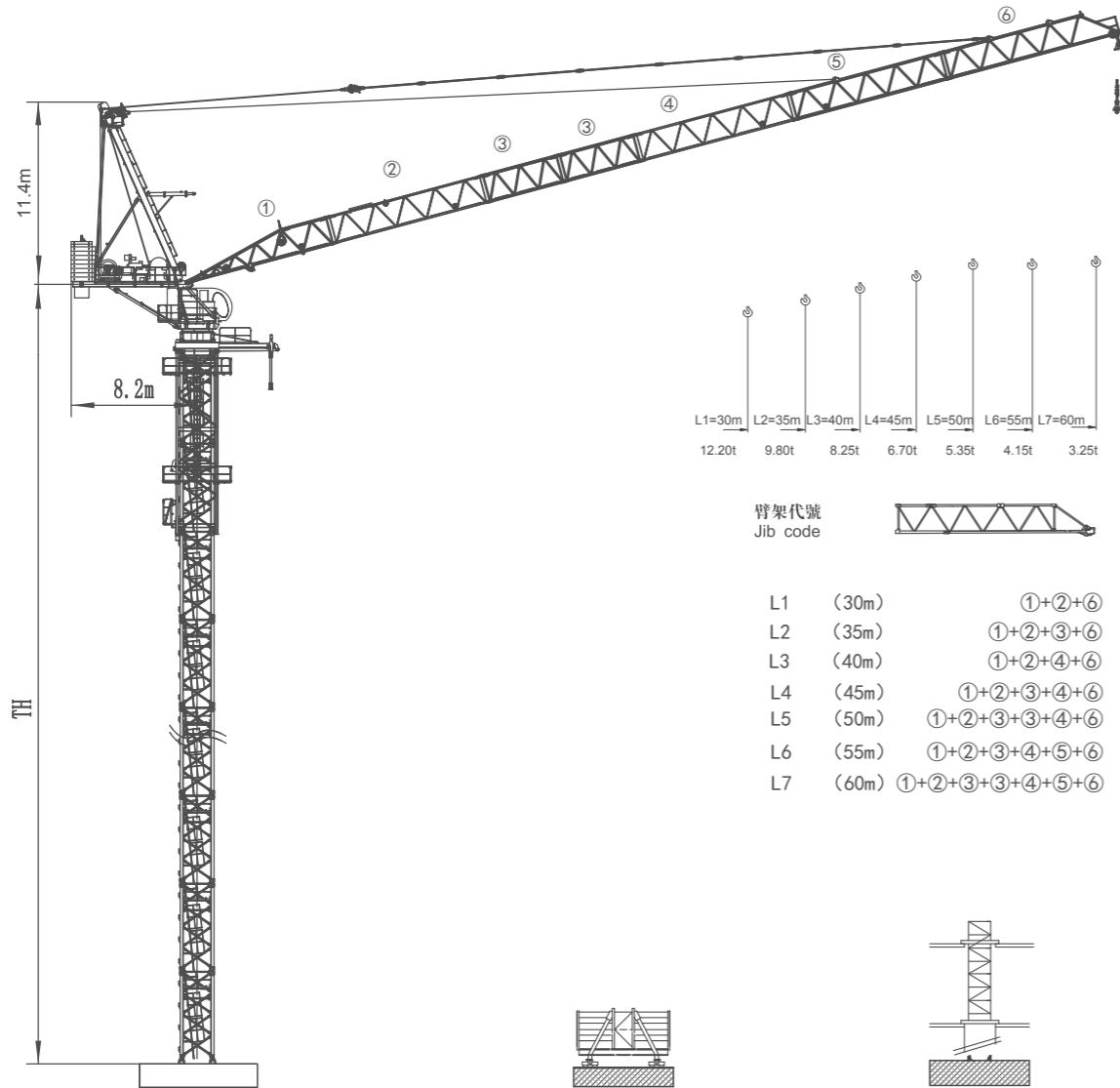

起重臂 Luffing Jib

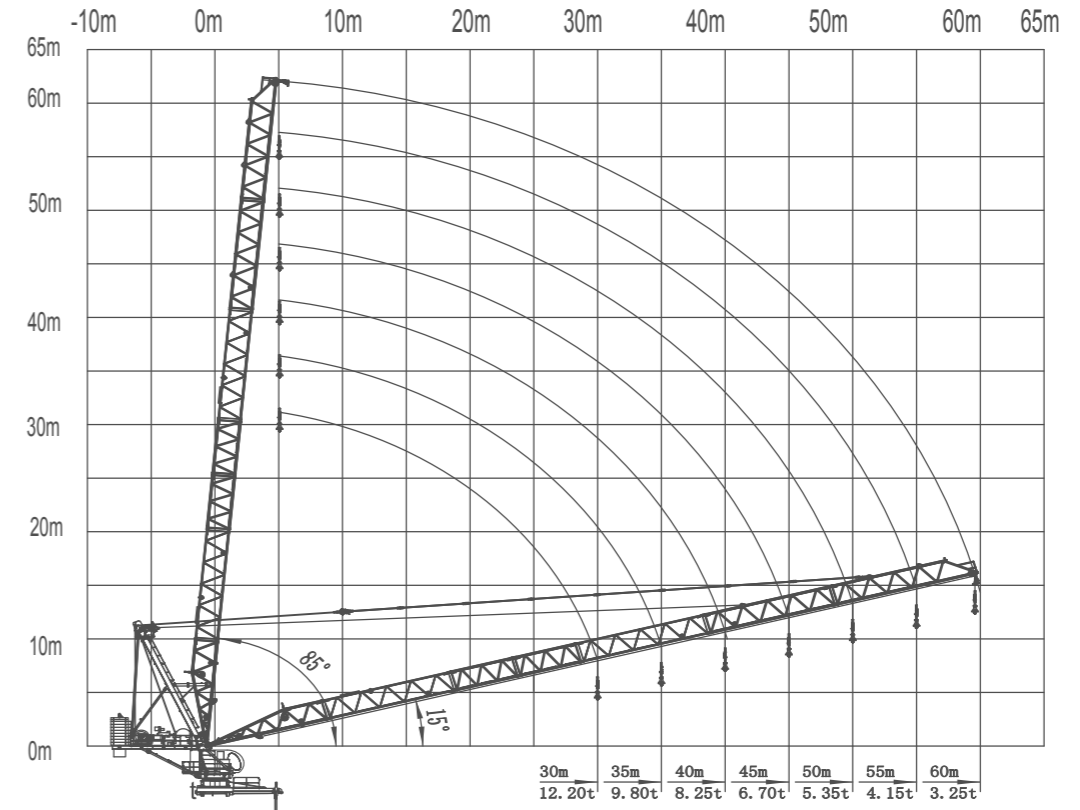

載荷表 Load Chart

R (m)	倍率 Fall	R (Cmax) (m)	Cmax (t)	10	15	20	25	30	35	40	45	50	55	60
60	II	33.38	9.00	9.00	9.00	9.00	9.00	9.00	8.40	6.87	5.66	4.70	3.91	3.25
	IV	23.17	13.50	13.50	13.50	13.50	12.31	9.78	7.96	6.59	5.52	4.66	3.95	
50	II	35.89	9.00	9.00	9.00	9.00	9.00	9.00	9.00	7.67	6.38	5.35		
	IV	20.28	18.00	18.00	18.00	13.97	11.05	8.96	7.38	6.14	5.15			
45	II	36.98	9.00	9.00	9.00	9.00	9.00	9.00	9.00	8.03	6.70			
	IV	21.03	18.00	18.00	18.00	14.61	11.59	9.42	7.78	6.50				
40	II	37.67	9.00	9.00	9.00	9.00	9.00	9.00	9.00	8.25				
	IV	21.53	18.00	18.00	18.00	15.04	11.95	9.73	8.05					
35	II	35.00	9.00	9.00	9.00	9.00	9.00	9.00	9.00					
	IV	21.65	18.00	18.00	18.00	15.14	12.03	9.80						
30	II	30.00	9.00	9.00	9.00	9.00	9.00	9.00						
	IV	21.88	18.00	18.00	18.00	15.34	12.20							

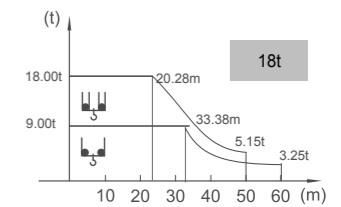

18t

18t

塔身截面 Mast ZL22 Reactions

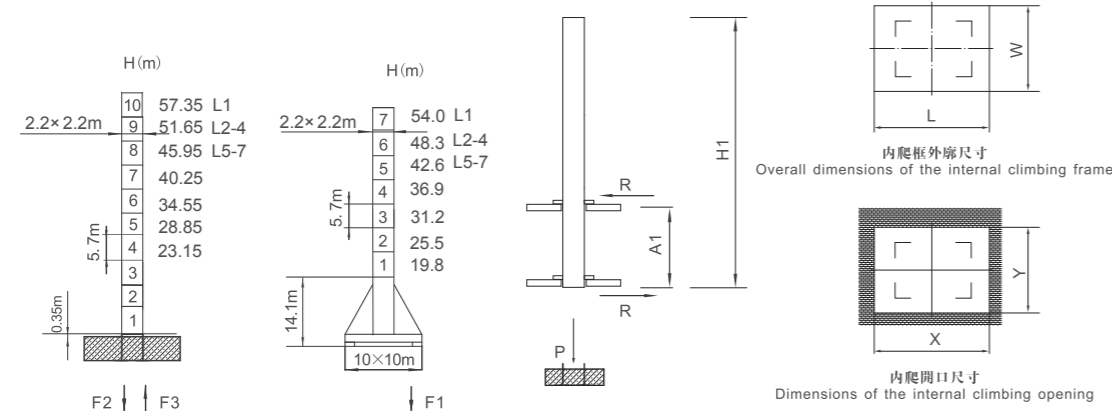

	●	■
F2	230t	257t
F3	155t	193t
⚙️	96t	

	●	■
F1	148t	159t
⚙️	106t	

塔身節 Mast	臂長 Jib length	H1 (m)	A1 (m)	P (t)	R (t)	X (m)	Y (m)
ZL22	L1	57.0	15-18	149	35		
	L2-4	51.3	15-18	145	35	*	*
	L5-7	45.6	15-18	141	35		

● 工作狀態支反力 In service reaction ■ 非工作狀態支反力 Out of service reaction
 ⚙️ 整機自由高度重量 (不含平衡重及壓重重量) Total weight of free standing crane (excludes counter weight & ballast)

附着 Anchoring

固定式附着高度 Anchoring height of stationary crane
 塔身截面 Mast □ 2.2×2.2m
 如需達到帶★高度或更高，請與我們聯系。
 When using ★ height or further, contact us please.

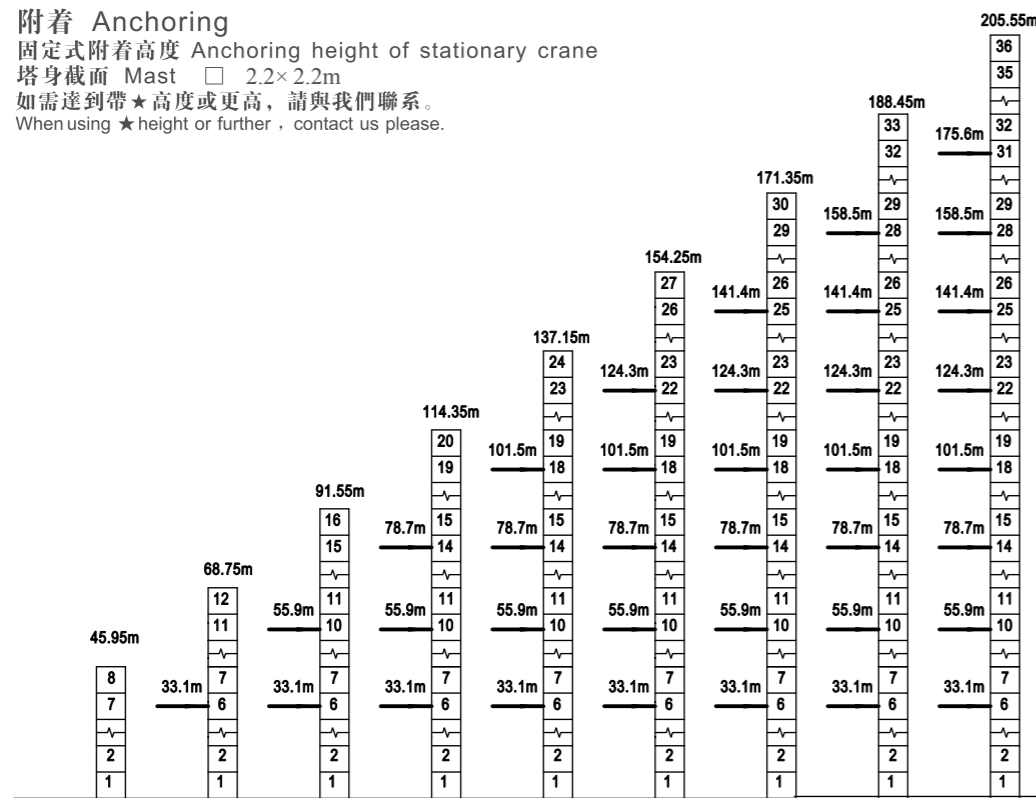

動臂系列

主要性能參數 Specifications

機構 Mechanism		⚙️		⚙️		電纜 Cable	電動機 Motor kW
		m/min	t	m/min	t		
18t	85LVF45A	0-35.0	9.0	0-17.5	18.0	700m	65
		0-52.5	6.0	0-26.0	12.0		
		0-84.0	3.0	0-42.0	6.0		
75DVF45K		15° -85° 2.6min					55
RVF7.5		0-0.7 rpm					2×7.5
RT		12.5-25 m/min					4×1.7/3.4
電壓 Pressure						kVA	
380V (±10%) 50Hz						180	

* 與製造商聯系 Contact us, please.
 ★ 標準配置 Standard configuration.

本技術參數不受法律約束，技術諮詢請詳見相應說明書或聯系我們。
 These specifications and data are not legally binding. For any technical information, please refer to corresponding instructions or contact us.

本技術參數不受法律約束，技術諮詢請詳見相應說明書或聯系我們。
 These specifications and data are not legally binding. For any technical information, please refer to corresponding instructions or contact us.